

#RAM SELECT	#IC202	#R290	#R291
2KX8 DIP24	MK48Z12-20	-	0S
8KX8 DIP28	MK48Z18	0S	-

() = PIN NUMBERS FOR MK48Z12

4A	CN:	90/09-474 & 90/12-639.	M.HALL	S.C.	S.C.	27/03/91
3A	CN:	90/03,105,126 90/05-201,202	D.H.	S.C.	S.C.	14/03/91
2A	CN:	90/01-02	DE	S.C.	S.C.	
C	CN:	89/11-633	DE	SNC	SNC	24/1/90
B	CN:	89/11-633	DBH	SNC	SNC	29/11/89
A	CN:	89/08-428	WD	HO	HO	18/10/89
	CN:	89/08-428	DEC	HO	HO	22/8/89
T99	CN:	89/08-428	HUIA	HO	HO	11/5/89
ISSUE:	ORIGINAL					

TITLE
T700 CONTROL BOARD
DIGITAL CCTRL

TAIT ELECTRONICS NEW ZEALAND
 DRAWING NO: C685 SHEET 2 OF 4 ISSUE 4D
 IPN: 220-01166-04
 FILE NAME: 116604D FILE DATE: 10/05/99

ASSEMBLY DRAWING SCALE:

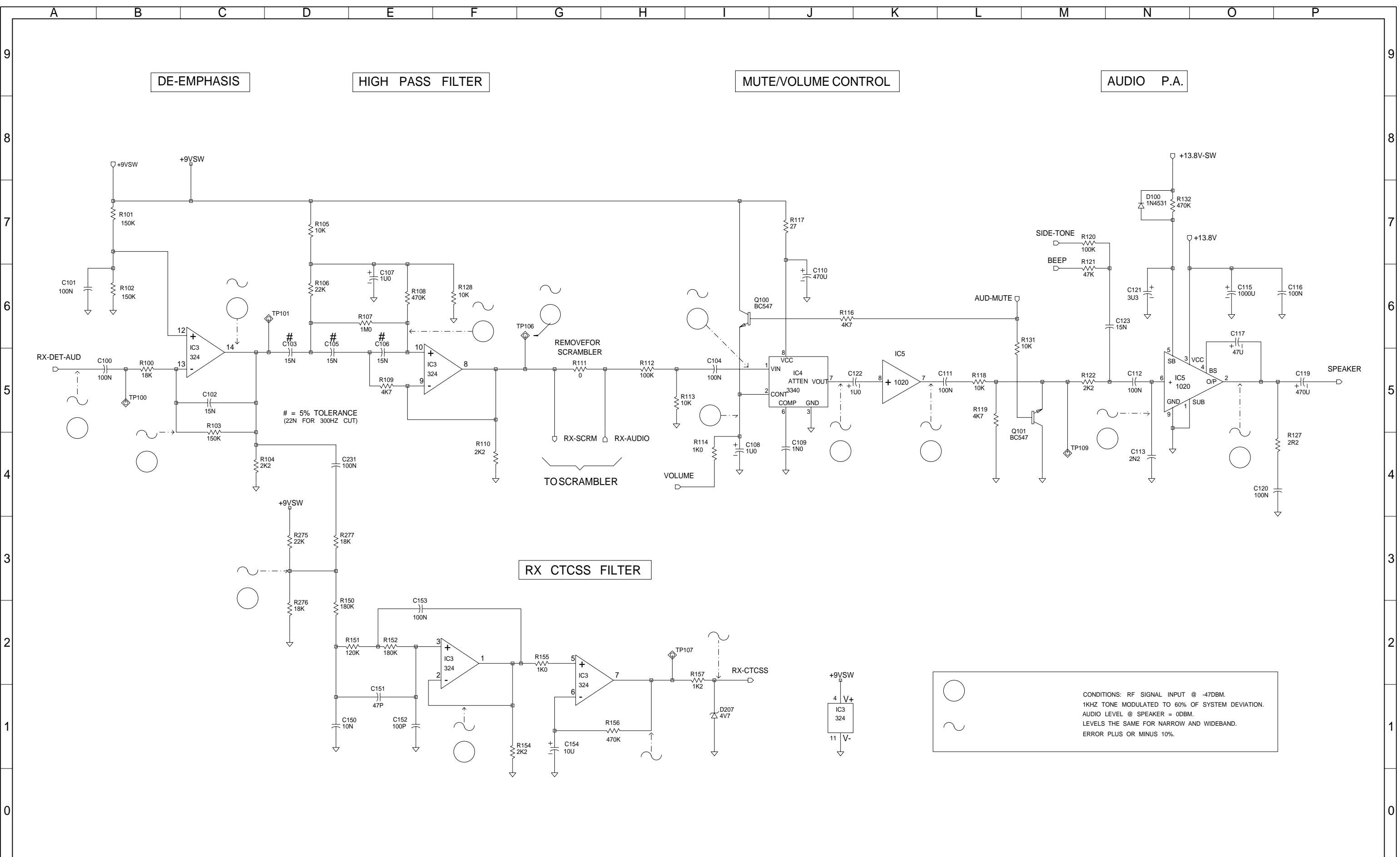

○
 ~

CONDITIONS: RF SIGNAL INPUT @ -47DBM.
 1KHZ TONE MODULATED TO 60% OF SYSTEM DEVIATION.
 AUDIO LEVEL @ SPEAKER = 0DBM.
 LEVELS THE SAME FOR NARROW AND WIDEBAND.
 ERROR PLUS OR MINUS 10%.

4A	CN: 90/09-474 & 90/12-639.	M.HALL	S.C.	S.C.	27/03/91
3A		D.H.	S.C.	S.C.	14/03/91
2A	CN: 90/03.105.126 90/05-201.202	DE	S.C.	S.C.	
C	CN: 90/01-02	DE	SNC	SNC	24/1/90
B	CN: 89/11-633	DBH	SNC	SNC	29/11/89
A	VOLTAGE OVERLAY	WD	HO	HO	18/10/89
A	UPDATED. CN: 89/08-428	DEC	HO	HO	22/8/89
T99	ORIGINAL	HUIA	HO	HO	
ISSUE:	AMENDMENTS:	DRAWN:	CHKD:	APVD:	DATE:

TITLE

T700 CONTROL BOARD

RECEIVER AUDIO

ASSEMBLY DRAWING SCALE:

TAIT ELECTRONICS NEW ZEALAND		
DRAWING NO: C685	SHEET 3	ISSUE
IPN: 220-01166-04	OF 4	4D
FILE NAME: 116604D	FILE DATE: 10/05/99	

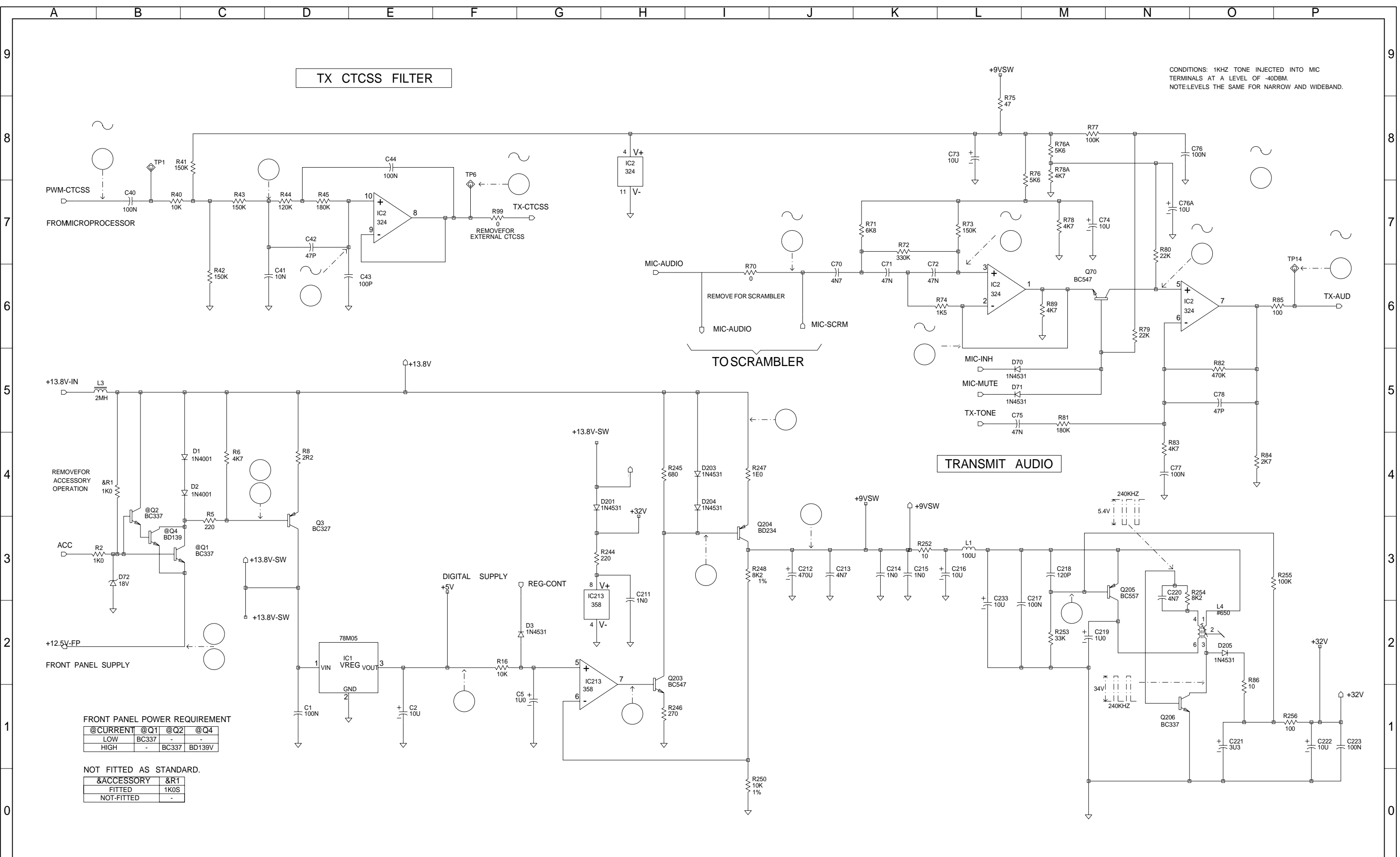

CONDITIONS: 1KHZ TONE INJECTED INTO MIC TERMINALS AT A LEVEL OF -40DBM.
NOTE: LEVELS THE SAME FOR NARROW AND WIDEBAND.

FRONT PANEL POWER REQUIREMENT

@CURRENT	@Q1	@Q2	@Q4
LOW	BC337	-	-
HIGH	-	BC337	BD139V

NOT FITTED AS STANDARD.

&ACCESSORY	&R1
FITTED	1K0S
NOT-FITTED	-

4A	CN: 90/09-474 & 90/12-639.	M.HALL	S.C.	S.C.	27/03/91
3A		D.H.	S.C.	S.C.	14/03/91
2A	CN: 90/03,105,126 90/05-201,202	DE	S.C.	S.C.	
C	CN: 90/01-02	DE	SNC	SNC	24/1/90
B	CN: 89/11-633	DBH	SNC	SNC	29/11/89
A	VOLTAGE OVERLAY	WD	HO	HO	18/10/89
A'	UPDATED. CN: 89/08-428	DEC	HO	HO	22/8/89
T99	ORIGINAL	HUIA	HO	HO	
ISSUE:	AMENDMENTS:	DRAWN:	CHKD:	APVD:	DATE:

TITLE
**T700 CONTROL BOARD
TX AUDIO AND REGULATORS**

TAIT ELECTRONICS NEW ZEALAND

DRAWING NO: C685	SHEET 4	ISSUE 4D
IPN: 220-01166-04	OF 4	
FILE NAME: 116604D	FILE DATE: 10/04/99	

ASSEMBLY DRAWING SCALE: